

Windows Installed into Walls with FPIS and Wood Framing

Standard Method

Revised 11/14/2016



Background

- There are many acceptable ways to mount and detail windows for support and weather resistance.
- This installation best practice provides only a representative solution for integrating windows with Foam Plastic Insulating Sheathing (FPIS).
- It is the responsibility of the user to verify the appropriateness of any specific detail for their specific conditions.

Scope

- The installation approach featured in this presentation:
 - Is a “standard” installation concept with window flanges mounted directly over a limited thickness of FPIS.
 - This represents the most common method for installing windows in walls with up to approximately 2-inches-thick FPIS.



Scope

- The installation approach featured in this presentation:
 - Uses FPIS as the water-resistive barrier (WRB).
 - Refer to [DrJ DRR 1410-05](#) and the FPIS manufacturer's installation instructions.
 - Use of a separate WRB material layer is also common and acceptable with appropriate installation and detailing.



Scope

- The installation approach shown includes windows with integral mounting flanges.
- Integral mounting flange windows:
 - Are sometimes referred to as “integral nailing flange,” “integral fin,” or “integral mounting fin.”
 - An integral flange is extruded with the frame and forms one continuous piece around the perimeter.
 - A mounting flange is typically about 1½” wide and is set back about 1” from exterior window face. Fasteners are installed through the pre-punched holes in the flange.



About FPIS

- Three types of FPIS:
 - Expanded Polystyrene (EPS) - ASTM C578
 - Extruded Polystyrene (XPS) - ASTM C578
 - Polyisocyanurate (Polyiso) - ASTM C1289
- R-values ranging from R-4 to more than R-6 per inch.
- Come in many thicknesses, compressive strengths, and densities.

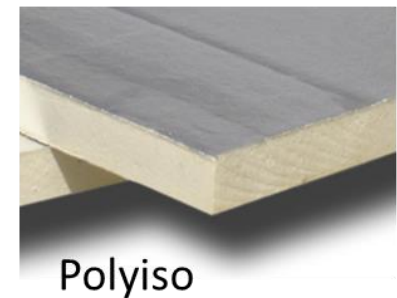
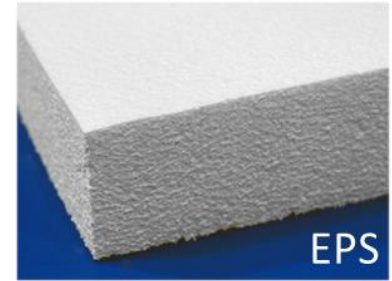

Typical FPIS Applications

- Often used as exterior **continuous insulation (ci)** on buildings to comply with energy codes or for improved performance.
 - Can be used as an **air-barrier (AB)** and **water-resistive barrier (WRB)** per manufacturer's code approvals and instructions.
 - Proprietary FPIS products are also available as a structural insulating sheathing composite for **wall bracing**.



Installation Guidance

- [DrJ Best Practices](#)
- Window, FPIS, WRB, or Flashing manufacturer's installation instructions
- An approved design
- The following general installation guidelines

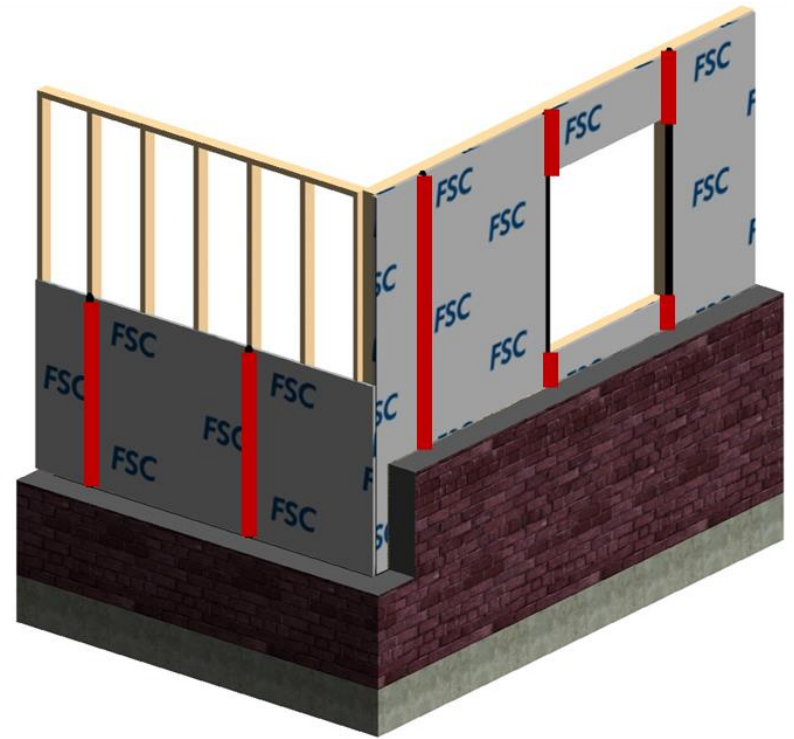

Key Principles

- The intent of any acceptable detail for integrating windows with FPIS is:
 - To provide adequate structural support to the window unit.
 - To prevent water penetration at the window-wall interface by flashing to direct water onto the exterior surface of the WRB layer and/or cladding and away from the window opening.
 - To provide adequate drainage at the window sill for any incidental leakage of water that may still penetrate into the rough opening.

Framing Methods

- There are four typical methods for window framing.
- This program covers the “Standard” method.

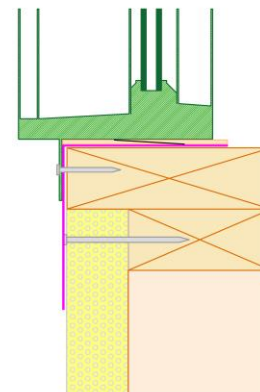
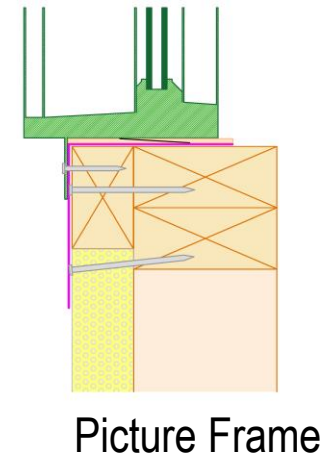
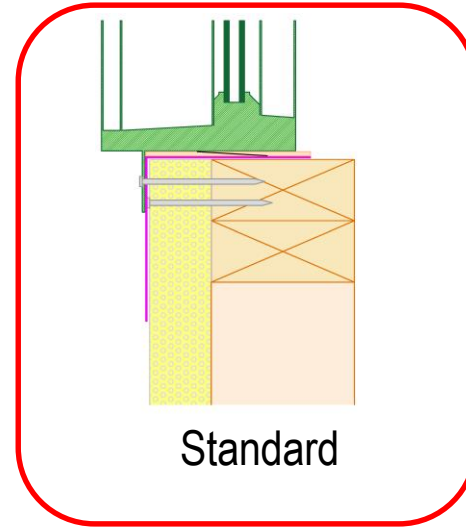

Lumber Window Buck

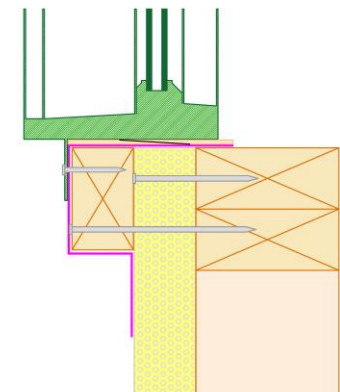

Rainscreen

Standard Installation - Sill

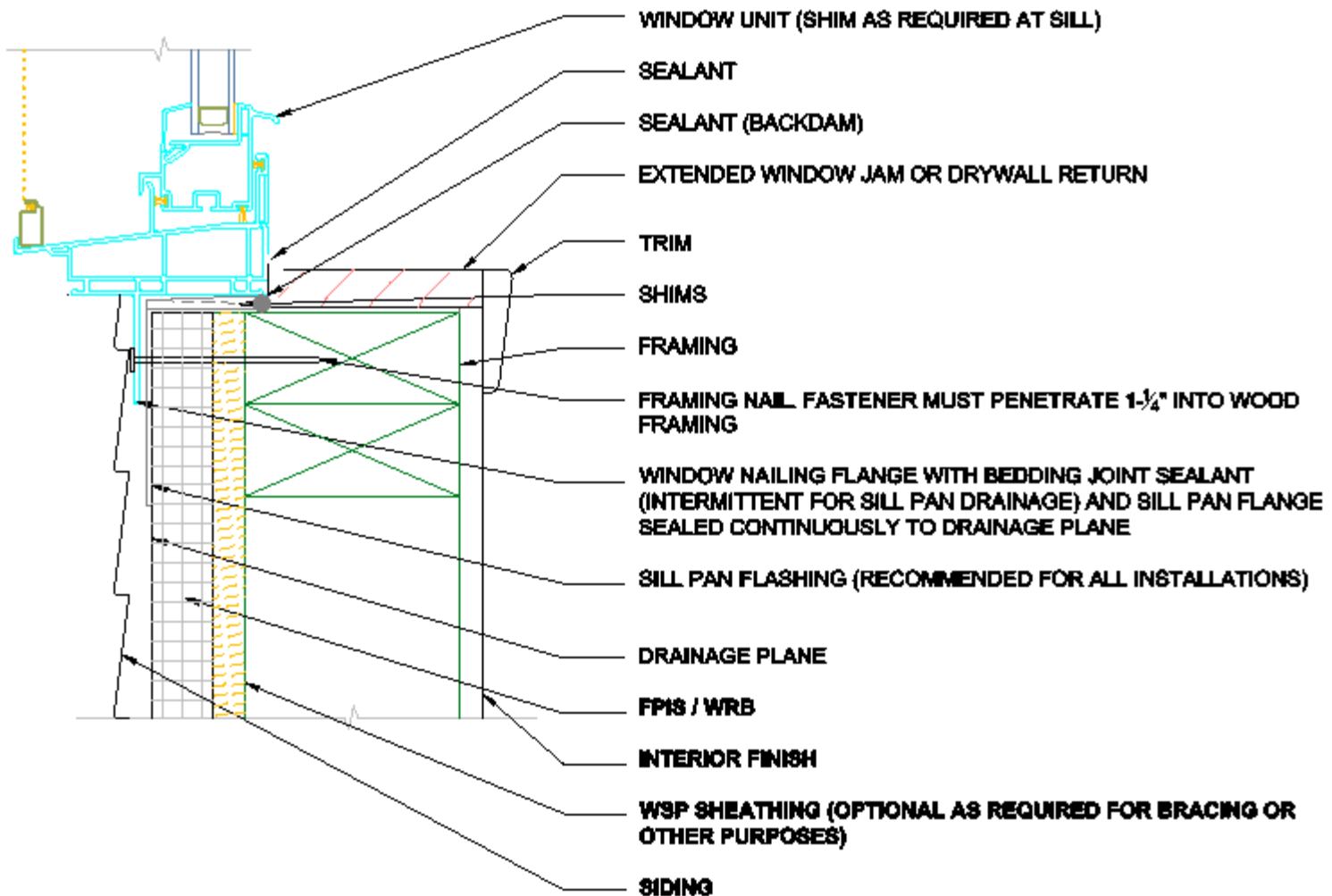

Standard Installation - Jambs

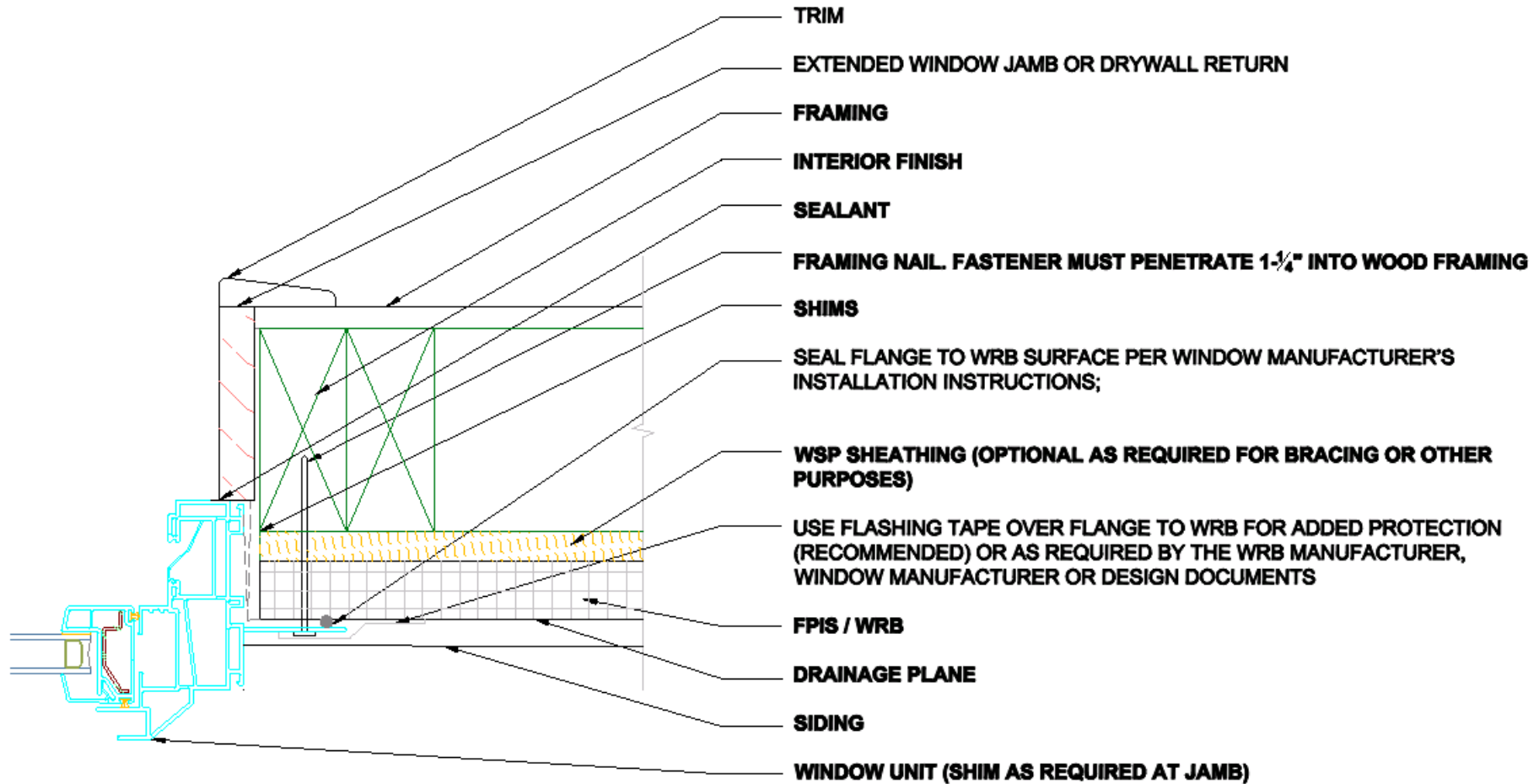

Standard Installation - Header

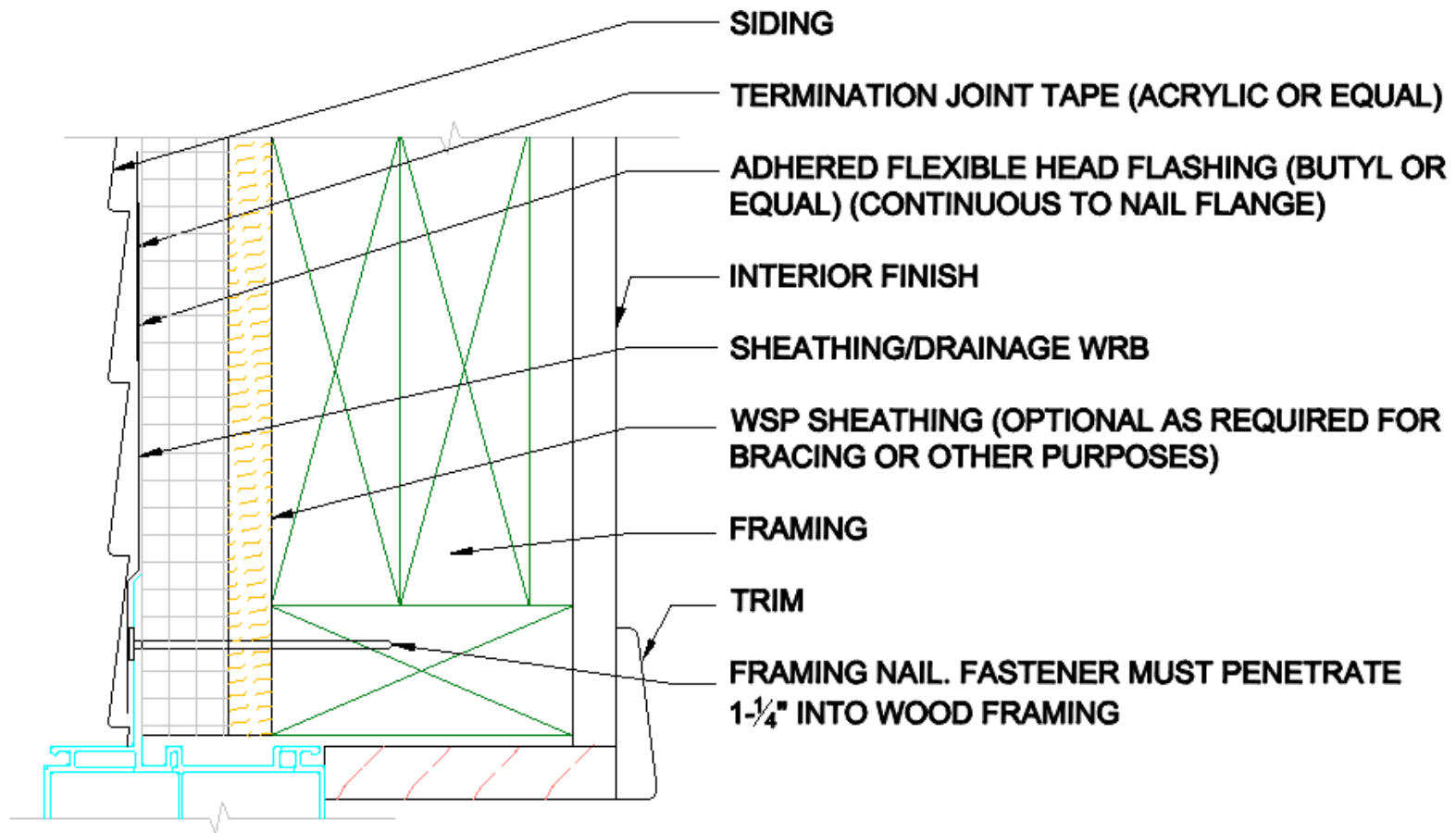

Step 1: Frame Window Opening

- Frame walls as required by the applicable code.
- Ensure window rough opening is square and true.
- Ensure appropriate framing in accordance with window installation method selected and support for FPIS edges is provided.

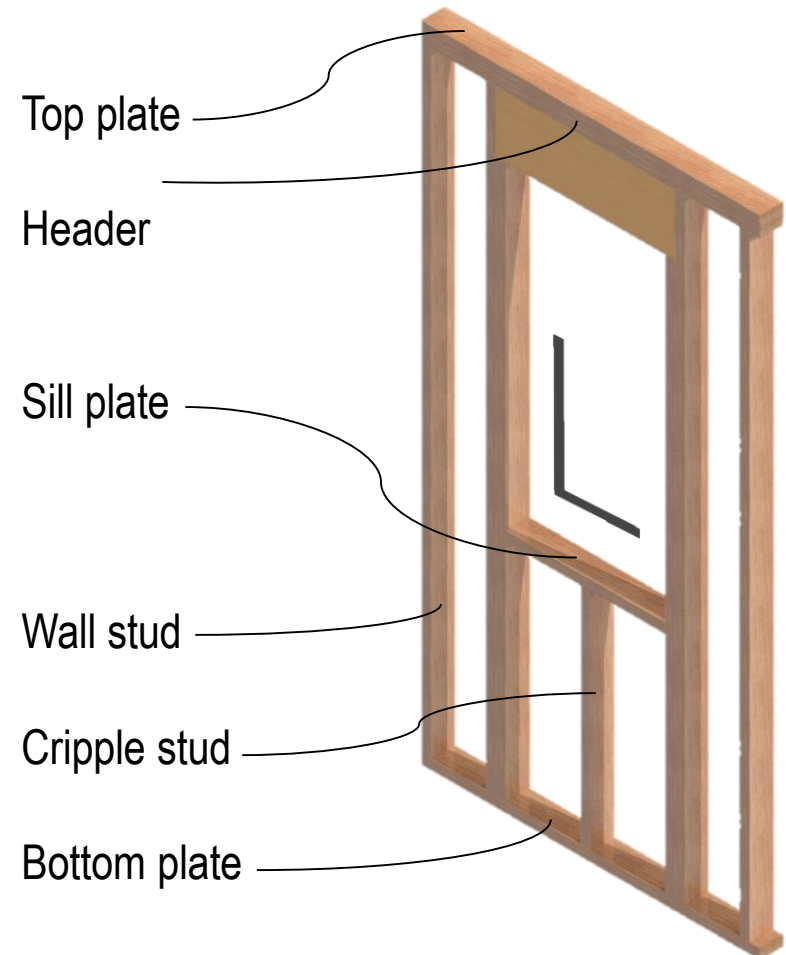

Step 2: Verify and Install FPIS

- FPIS material must comply with:
 - ASTM C578 (EPS, XPS)
 - ASTM C1289 (Polyiso)
- Minimum 15 psi FPIS recommended
 - For window flanges bearing on FPIS ([DRR 1304-01](#))
 - For cladding and furring attachments through FPIS ([DRR 1303-04](#))
- Maximum foam thickness = 2"
- Wind pressure resistance
 - See [ANSI/SBCA FS-100](#) for guidance
 - Only required when FPIS not used as oversheathing

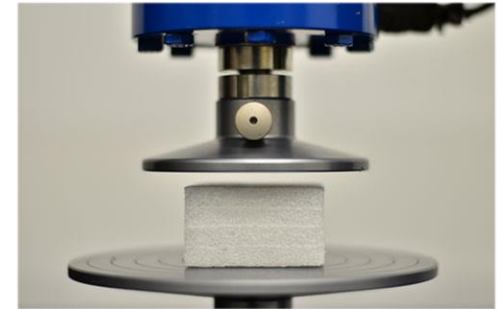

ASTM D 1621

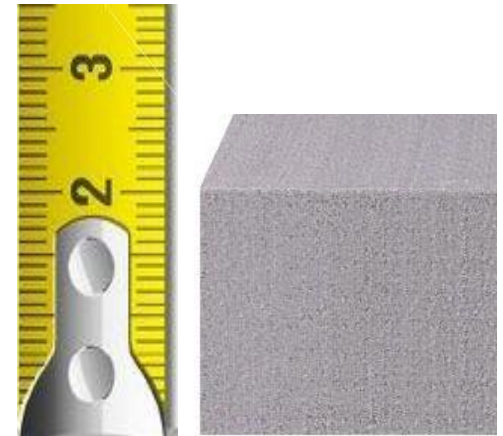

Step 2: Verify and Install FPIS

- Drive nails flush and snug with the surface of the insulation board.
- Do not overdrive nails.
- Do not underdrive nails.
- Many FPIS manufacturers recommend use of cap nails.

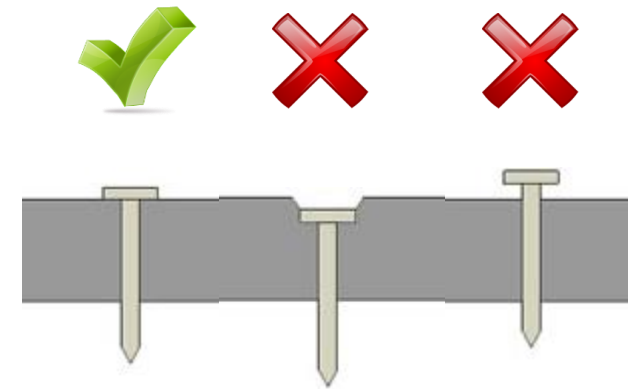

Step 2: Verify and Install FPIS

- Follow manufacturer's installation guidelines
- While not prohibited, avoid placing vertical joints in the sheathing over a window head where practical.
- See “[FPIS Installation Instructions](#)” program.



Step 3: Verify Flashing and Sealant Materials

- Ensure chemical compatibility of all sealants and flashings with intended substrates; refer to sealant and flashing manufacturer's data.
- Use flashing tape and sealants recommended by the window and FPIS/WRB manufacturers.



Step 4: Apply Sill Flashing

- Apply all flashings in shingle fashion (e.g., jamb flashing overlaps sill flashing and head flashing overlaps jamb flashing).
- Overlap and seal sill flashing at center of sill if a multi-piece sill or pan flashing is used.

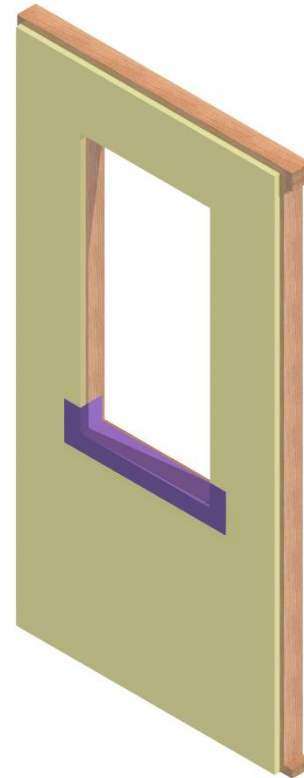

Step 4: Apply Sill Flashing

- Alternatively, use a manufactured sill pan to simplify sill drainage installation.



Manufactured Sill Pan

Step 5: Apply Sealant

- Apply sealant at jambs and head (or as required by manufacturer's install instructions).
- Sill is left open to allow the cavity below the window to drain to the exterior.

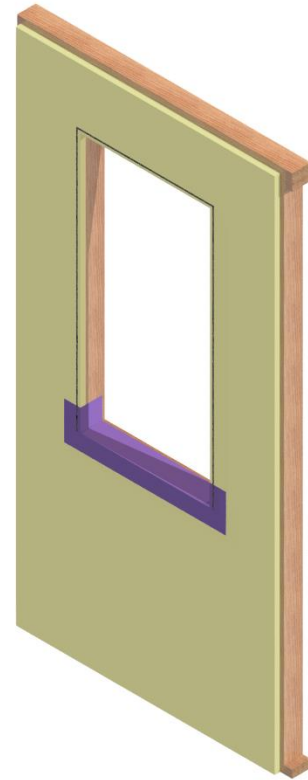

Step 6: Install Window Shims at Sill

- Apply setting blocks and/or shims between the rough opening and window frame.
- The window frame must be anchored to the wood rough opening as required by the window manufacturer or in accordance with an approved design for sill support.



Step 7: Install Window

- Install window plumb, level, and square per manufacturer's instructions.



Step 7: Install Window

- The window frame must adequately bear on the sill particularly if using a non-structural flange window.
- A designed solution or sill lumber extension is required if adequate bearing is not present.
- Providing adequate sill support is good practice and often required by window manufacturer installation instructions.

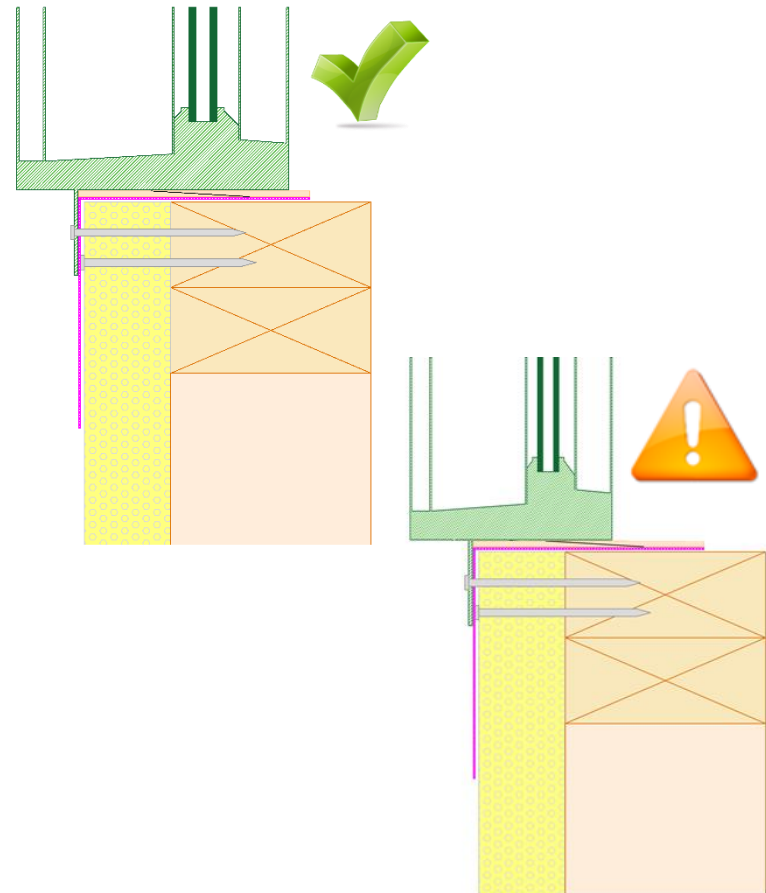

Step 8: Verify Window Fasteners

- Window flange fasteners must penetrate a minimum of 1¼" into framing members per IRC 2015.
- Follow manufacturer installation requirements for size and spacing.

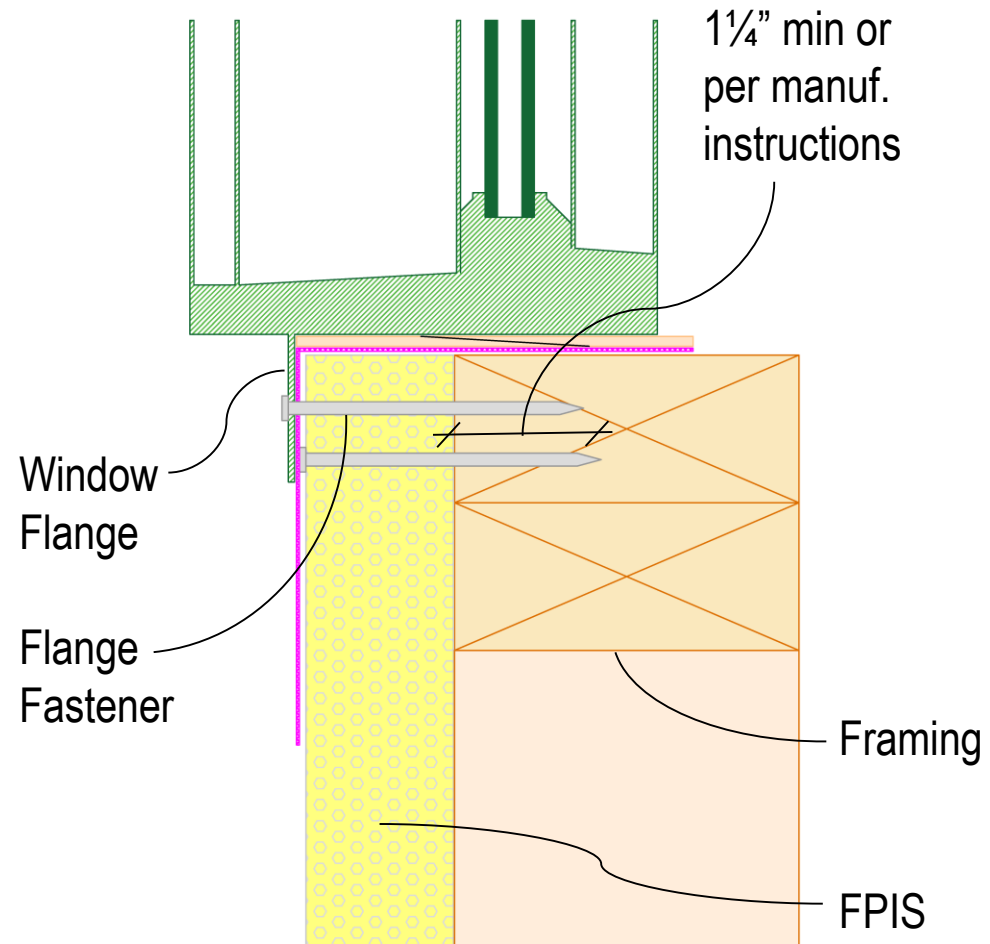

Step 8: Verify Window Fasteners

- Minimum fastener size and maximum spacing along window flanges (DRR 1304-01).
- See table notes.

Minimum Fastener (or equal)	Thickness of Foam Sheathing (in.)	Maximum Fastener Spacing in Flanges per Width of Window Unit	
		≤ 3'	> 3'
0.120"-Diameter Roofing Nail	½"	16" o.c.	9" o.c.
	1"	10" o.c.	5" o.c.
	1½"	7" o.c.	3.5" o.c.
	2"	6" o.c.	3" o.c.

1. Values assume integral flanges with fasteners that support 100% of window unit weight even when sill shims are installed per the manufacturer's installation instructions.
2. Table is based on a window unit weight of 7 pounds per square foot. For different weights, multiply fastener spacing by $7/w$, where w is the actual weight in pounds per square foot.
3. The fastener spacing provided in this table are the maximum allowed, based on support of the window unit's weight.
4. For wind load resistance, a lesser fastener spacing may be specified in the window manufacturer's installation instructions.
5. The window manufacturer's installation instructions, where more stringent, shall be followed, in the event of any conflict.
6. Spacing calculations in table assume that vertical flanges support 100% of the gravity load.

Step 8: Verify Window Fasteners

- Follow [DRR No. 1304-01](#) or window manufacturer's spacing instructions, if more stringent.

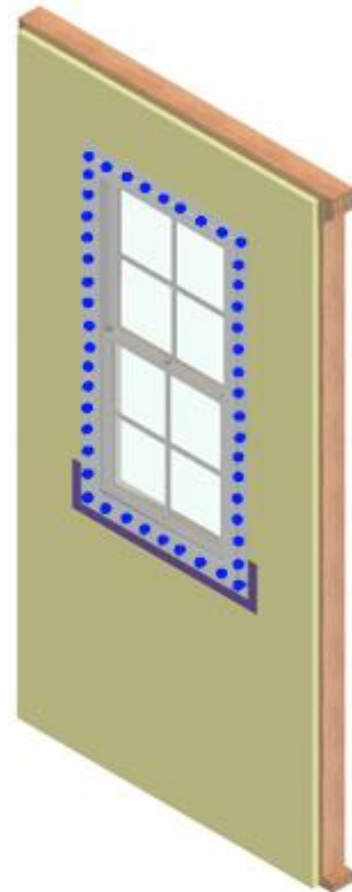

Step 9: Install Window Shims

- Apply shims between the rough opening and window frame.
- Anchor the window per the manufacturer's installation instructions.



Step 10: Apply Jamb Flashing

- Install flashing over the nailing flanges of the jambs to provide a final layer of protection against water intrusion.
- The sill is not sealed, allowing for drainage of the rough opening, back to the exterior.
- Where applicable, install drip cap per manufacturer



Step 11: Apply Head Flashing

- Apply head flashing.
 - Typically, butyl flashing tapes are used for this purpose.
- Overlap window head flange and jamb flashing.



Step 12: Tape Head Flashing

- For extra durability and protection, terminate the top edge of the head flashing tape with the FPIS manufacturer's approved joint tape.
- Typically, acrylic tapes are used for this purpose.



Step 13: Apply Sealant

- Air seal window around entire perimeter on the interior with sealant or expanding foam made for this purpose.



Step 14: Install Cladding

- [See Installation Instructions](#)
“Attachment of Exterior Wall Coverings Through Foam Plastic Insulating Sheathing (FPIS) to Wood or Steel Wall Framing.”



Additional Reading

- *Fastening Systems for Continuous Insulation*, New York State Energy Research and Development Authority (NYSERDA), April 2010.
- *ASHRAE Journal*, “[Stuck on you](#),” Feb 2013.
- *ASHRAE Journal*, “[Windows can be a pain](#),” Lstiburek, April 2015.